



# Mechanic's Guide

This guide is designed to help mechanics perform routine service and troubleshoot the Western snowplow. When used properly it will help you isolate service problems without the use of test equipment.

We encourage the use of the Western HYDRA-ELECTRIC™ Test Kit (Part No. 49120), a customized set of diagnostic tools developed to help troubleshoot problems accurately and perform pre-season tune-ups.

For service problems involving disassembly and repair of the hydraulic unit, see the Western Service Manual or consult your Western distributor.

Remember: Only genuine Western replacement parts conform to important design specifications, fit right and ensure that your Western plow warranty is maintained.

## TABLE OF CONTENTS

Safety .....	Page 2
Inspection and Routine Service .....	Page 3
Theory of Operation .....	Page 4-5
Troubleshooting .....	Page 6-7
Service Parts .....	Page 8

# SAFETY GUIDELINES

TO PREVENT ACCIDENTS THAT COULD RESULT IN SERIOUS INJURY AND/OR DAMAGE TO YOUR VEHICLE OR EQUIPMENT, CAREFULLY FOLLOW THESE SAFETY RULES AND TEST PROCEDURES.

## GENERAL

Be sure to disconnect the plow prior to performing any tests or making adjustments.

## SAFETY EQUIPMENT

### Fire Extinguisher

Never work on your vehicle without having a suitable fire extinguisher handy. A 5-lb. or larger CO<sub>2</sub> or dry chemical unit specified for gasoline/chemical/electrical fires is recommended.

## SAFETY GOGGLES

We recommend wearing safety goggles when working on your vehicle to protect your eyes from battery acid, gasoline, and dust and dirt flying off moving engine parts.

## LOOSE CLOTHING AND LONG HAIR (MOVING PARTS)

Be very careful not to get your hands, hair, or clothing near any moving parts such as fan blades, belts, and pulleys. Never wear neckties or loose clothing when working on your vehicle.

## JEWELRY

Never wear wrist watches, rings, or other jewelry when working on your vehicle. You'll avoid the possibility of catching on moving parts or causing an electrical short circuit which could shock or burn you.

## VENTILATION

The carbon monoxide in exhaust gas is highly toxic. To avoid

asphyxiation, always operate vehicle in a well ventilated area. If vehicle is in an enclosed area, exhaust should be routed directly to the outside via leakproof exhaust hose.

## SETTING THE BRAKE

Make sure that your vehicle is in park or neutral and that the parking brake is firmly set.

## HOT SURFACES

Avoid contact with hot surfaces such as the engine, radiator, and hoses.

## SMOKING AND OPEN FLAMES

Never smoke while working on your vehicle. Gasoline vapor is highly flammable, and the gas formed in a charging battery is explosive.

## BATTERY

Do not lay tools or equipment on the battery. Accidentally grounding the "HOT" battery terminal can shock or burn you and damage wiring, the battery or your tools and testers. Be careful of contact with battery acid. It can burn holes in your clothing and burn your skin or eyes. Disconnect the cable from the negative battery terminal before replacing the motor, solenoid or cab control.

(During Electrical Diagnosis)

 **WARNING:** Protect top of battery. Sparks from testing operations could cause battery gases to explode causing severe eye or body burns or other personal injury.

## HYDRAULIC SAFETY

Be sure to replace frayed, kinked, cracked or otherwise damaged hydraulic components.

## NOTE:

**Manufacturer assumes no liability for accidents or damages notwithstanding the fact that suggestions have been followed.**

The following are registered® or unregistered trademarks™ of Douglas Dynamics, Inc.

WESTERN® ISARMATIC® HYDRA-TURN® HYDRA-LECTRIC™

# INSPECTION AND ROUTINE SERVICE

## GENERAL

Scratching, denting or marring machined surfaces can make parts unserviceable. Cleanliness is essential when servicing the unit.

The following recommendations are intended as a general guide for regular care and maintenance. Operating under adverse conditions or sustained loads requires more frequent servicing.

## CHECKLIST

1. Check oil level with unit on vehicle and ram collapsed. If low, fill to top of reservoir fill hole, located at rear of housing.

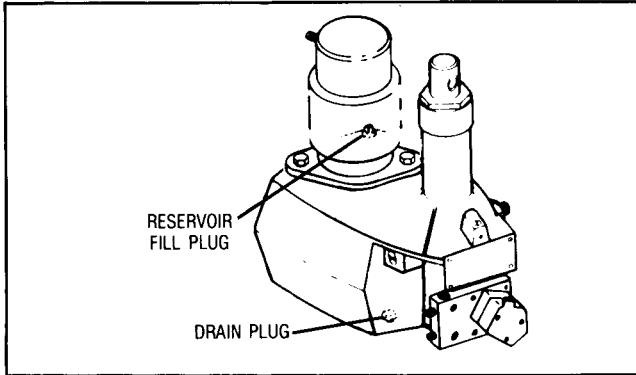

### NOTE:

**Be sure to fill through reservoir fill hole. Never fill through motor/pump opening if, for instance, motor has been removed for servicing. Filling through motor/pump hole can cause overfilling and damage entire unit.**

Use automatic transmission fluid. If that is not available you may also use SAE 10W nondetergent motor oil (SAE 5W in extreme cold).

Capacity of the system is summarized in the following chart. Note that the system holds less if Hydra-Turn® rams and hoses have not been drained.

MODEL (Ram Dia.)	ISARMATIC® RESERVOIR	HYDRA-TURN® RAMS AND HOSES	TOTAL
1-1/2"	1-1/2 qt.	5/8 qt.	2-1/8 qt.
2"	1-1/2 qt.	1-1/4 qt.	2-3/4 qt.

2. Drain and flush the hydraulic reservoir at the end of each plowing season. Use the drain plug located in the bottom front of the reservoir.
3. If rams are leaking excessively, tighten packing nuts. Do not tighten more than 1/4 turn after you feel the nut contact the packings. If leak continues, replace packings and wiper ring in nut. Over-tightening affects cylinder operation and packing life.
4. Check 3-way and 4-way valves for excessive oil leaks. Replace O-rings if they are damaged.
5. Periodically clean and tighten all electrical connections.
6. At beginning of plowing season, inspect and test battery. Recharge or replace, if necessary. Suggested MINIMUM vehicle electrical system: 70 amp hr./550 CCA Battery 55 amp Alternator.
7. The pump inlet filter screen should be cleaned whenever the pump is removed. If the screen is damaged, replace it.

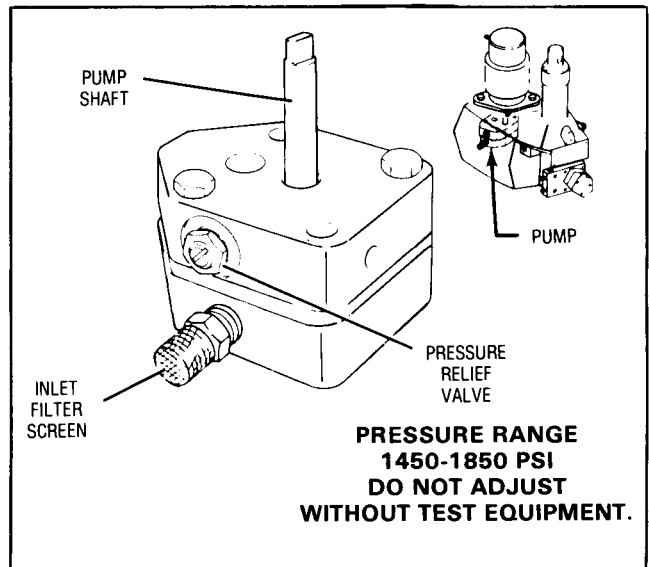

8. During periods of inactivity, leave the Isarmatic® ram collapsed. This will prevent damage to the chrome surface of the plunger. Also, coat the exposed surfaces of the Hydra-Turn® rams with grease to prevent rust or corrosion.

# THEORY OF OPERATION

The Isarmatic® Mark IIIa Hydraulic System performs four functions:

Raises the snowplow

Lowers the snowplow

Angle snowplow right

Angle snowplow left

Three of these functions (Raise, Angle Right, Angle Left) are accomplished by electrical and mechanical means. The fourth (Lower) operates only by mechanical means.

## ELECTRICAL

When the cab control is in the RAISE, LEFT (L) or RIGHT (R) position, contacts inside the control are grounded. That completes the solenoid (primary) circuit, energizing the solenoid. When the contacts inside the solenoid close, the battery/motor (secondary) circuit is completed. A direct, low resistance current path is now available to energize the electric motor. Current flows from the battery; through the contacts in the solenoid; through the motor; and through the motor ground terminal into the ground circuit back to the battery.

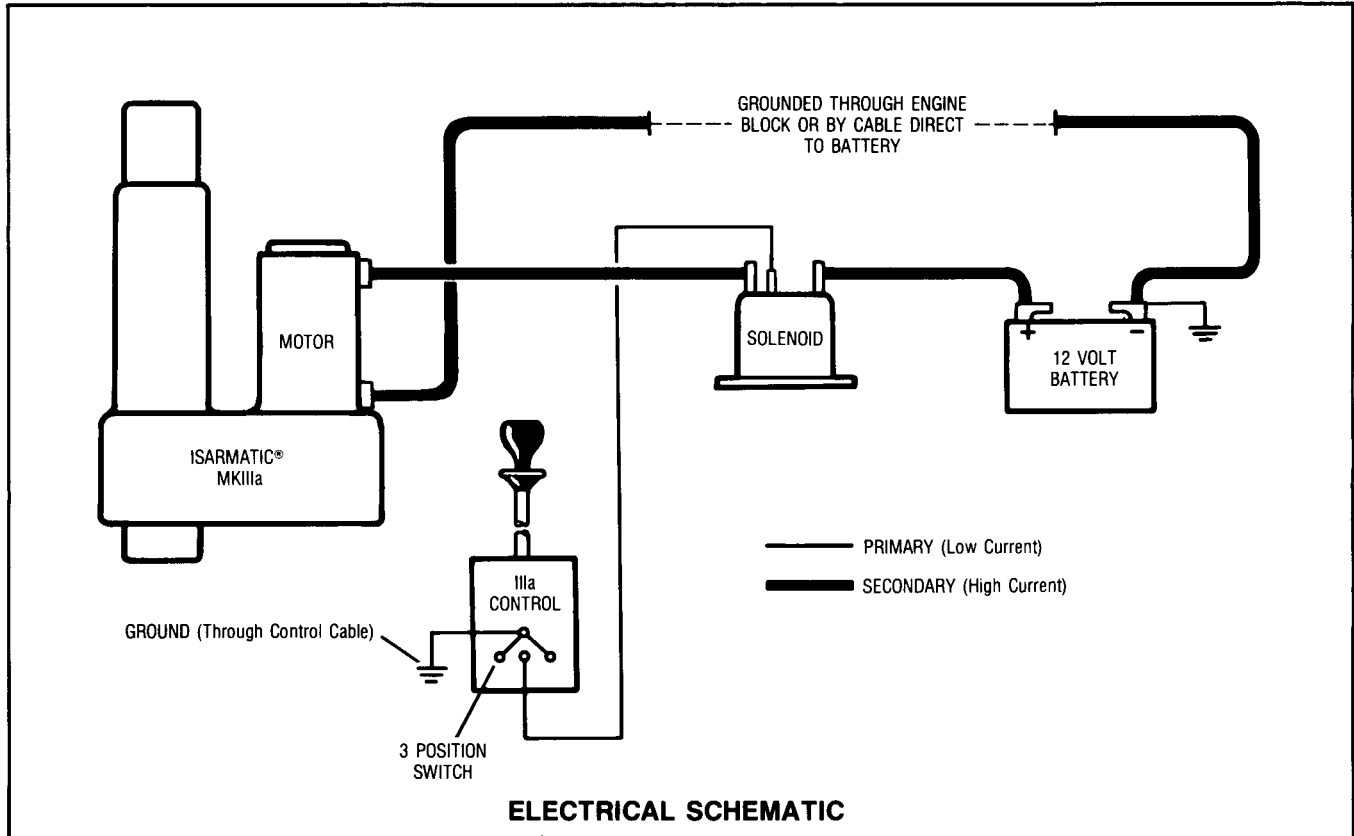

## RAISING PLOW

The shuttle is moved into the lift valve. This closes the passageway to the reservoir and directs flow from the pump outlet to the lift ram. Oil passes through the 4-way valve and into the 3-way valve. It flows around the shuttle stem and pushes the check valve ball off its seat. It then enters the lift ram, pushing the plunger (and snowplow blade) up.

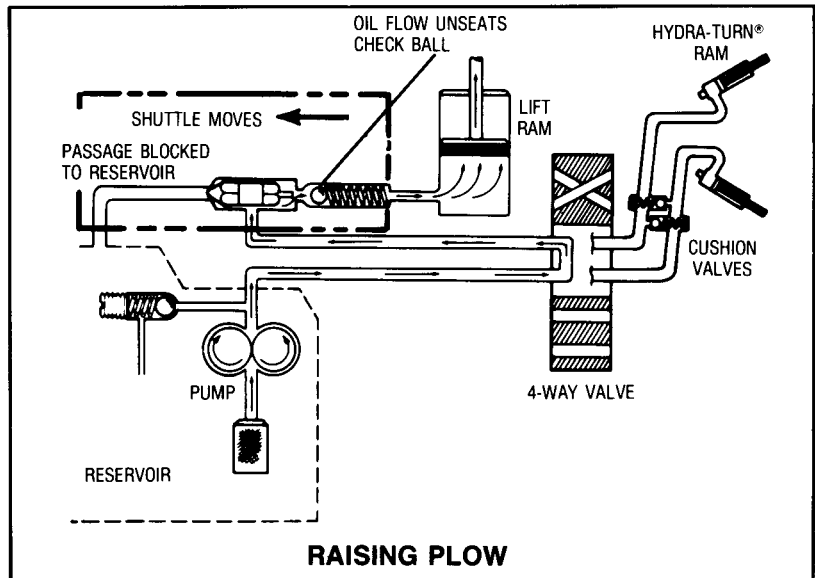

# THEORY OF OPERATION (CON'T.)

## LOWERING PLOW

The shuttle is moved away from the lift valve and pushed against the check valve ball. This opens a passageway from the lift ram to the reservoir. Weight of the snowplow collapses the ram, forcing oil past the open check valve and shuttle, back to the reservoir. Note that the pump does not operate when the plow is being lowered.

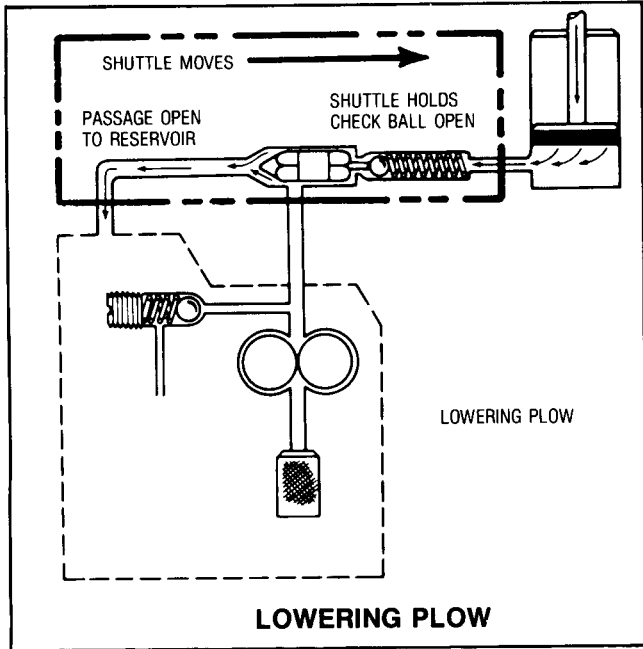

## RIGHT OR LEFT PLOW ANGLING BY 4-WAY VALVE

**RIGHT (Fig. A)** The rotor is rotated 45° clockwise so the recessed pockets provide passages between the pump supply and left Hydra-Turn® ram and the reservoir port. Oil from the pump flows through 4-way valve and enters the left Hydra-Turn® ram. As the cylinder extends the plow angles to the right. As plow angles, the right Hydra-Turn® ram collapses, pushing oil through the 4-way valve and past the shuttle in the 3-way valve to the reservoir.

**LEFT (Fig. B)** The rotor is rotated counterclockwise reversing the connections of Hydra-Turn® rams, pump supply, and reservoir port.

## CUSHION VALVES (2) (See Fig. C Below)

While plowing, oil is trapped in the extended Hydra-Turn® ram. When the blade meets an object, pressure rises in the extended Hydra-Turn® ram. As pressure in the ram exceeds the spring force holding the checkball against the seat, the cushion valve ball unseats allowing oil to flow to the collapsed ram. The blade angles in the opposite direction preventing damage to the hydraulic system and vehicle.

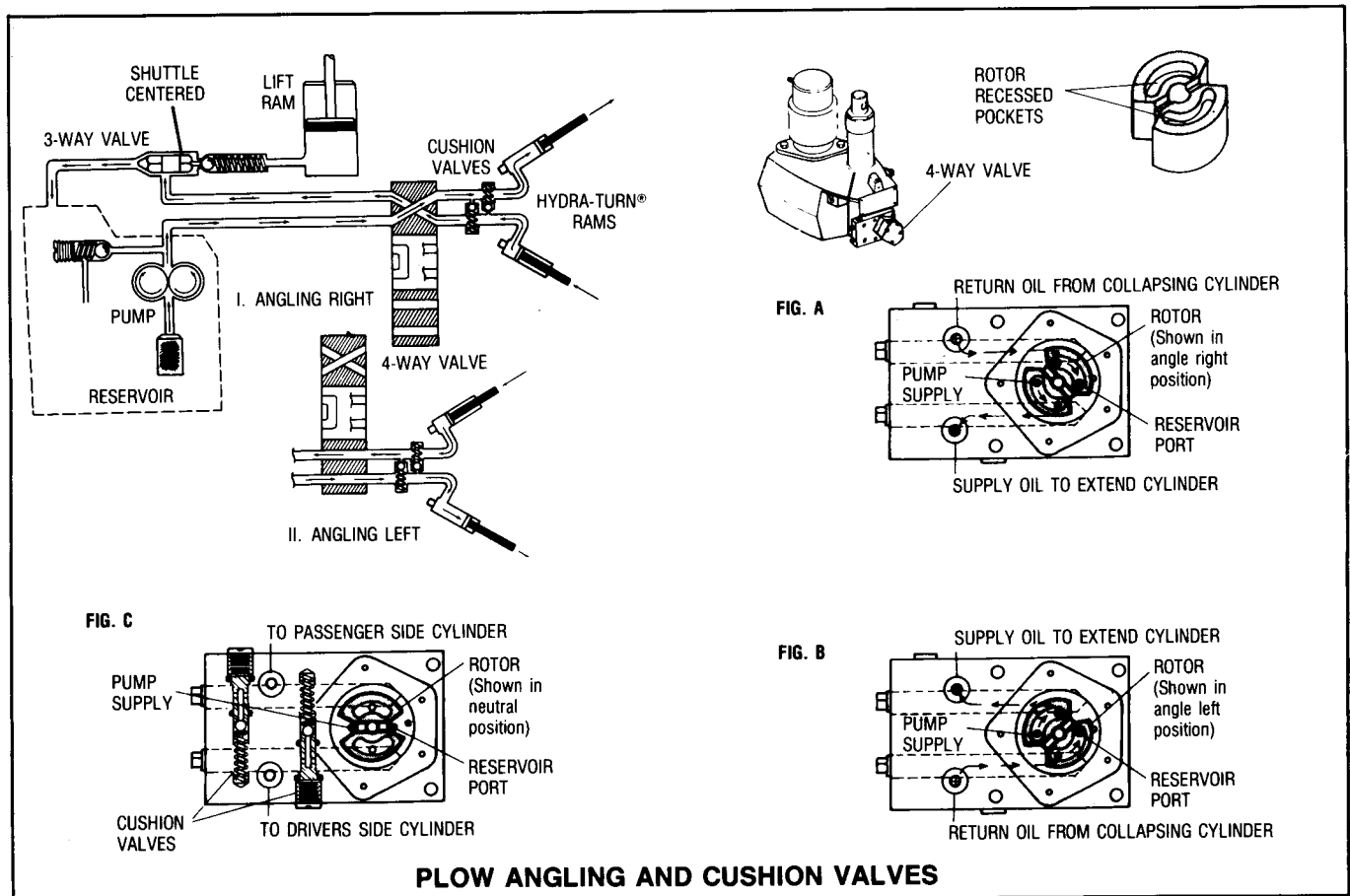

# TROUBLESHOOTING AND TUNE-UP GUIDE

Cab Control Position	PROBLEM DESCRIPTION	DEFINE PROBLEM AND FOLLOW STEPS BELOW.						
Angle	Blade will not angle or angles too slow. Time: 4 seconds; (8 seconds — Heavy-Duty).	Check if motor runs, if not, see Electrical Diagnosis <b>B</b>	Check oil level. (Page 3)	Verify 4-way valve lever travel. See C.	Adjust lift valve out. See E1.	Check disconnect couplers & Hydra-Turn® ram nuts.	Remove Pump. Clean filter screen.	
Raise	Blade will not raise or raises too slow. Time: 2 seconds; (4 seconds — Heavy-Duty).			Verify 3-way valve lever travel. See C.	Adjust lift valve in. See E1.	Check lift ram packing nut.		
Neutral	Blade will not remain angled while plowing.	Adjust cushion valves. See A.					<b>FURTHER TROUBLESHOOTING REQUIRES THE USE OF TEST EQUIPMENT. SEE AUTHORIZED WESTERN DISTRIBUTOR OR SEE WESTERN HYDRA-LECTRIC™ TEST KIT AND/OR WESTERN SERVICE MANUAL.</b>	
Neutral	Motor continues to run in neutral.	Disconnect cab control wire from solenoid.	If motor runs, solenoid is shorted. Replace solenoid. If motor stops, short is in primary (cab control) circuit. Isolate and repair.					
Angle	Blade raises while angling.	Verify 3-way valve lever travel. See C.	Adjust lift valve (out). See E1.					
Neutral	Blade lowers in neutral.		Adjust check valve (out). See E2.	Remove check valve. Inspect O-ring & seat. See Service Manual.				
Lower	Blade lowers too fast.							
Lower	Blade will not lower or lowers too slow.		Adjust check valve (in). See E2.	Check lift ram packing nut.				

## GENERAL INFORMATION

Remember that most service can be performed with the hydraulic unit left on the vehicle. This should be done whenever possible because it permits evaluation of the entire system (vehicle electrical system, cables, cab control, etc.) as well as saving considerable time.

Be sure to disconnect the negative battery terminal before replacing the motor, solenoid or cab control.



**CAUTION** — Do not stand between the vehicle and plow when it is being raised or angled. CLEARANCE BETWEEN VEHICLE AND PLOW IS DECREASED AS PLOW IS RAISED OR ANGLED.

## A CUSHION VALVE ADJUSTMENT

Tighten cushion valve stem as much as possible (until spring is fully compressed). Then, back off valve stem (rotate counterclockwise) 1-¼ turns. This adjustment will cause the cushion valve to open at approximately 3500 PSI.

**PACKING NUT ADJUSTMENT**—ISARMATIC® or HYDRA-TURN® RAMS  
If leaking, tighten packing NOT MORE THAN 1/4 TURN AFTER YOU FEEL PACKING NUT CONTACT PACKINGS. Over-tightening affects cylinder operation and packing life.

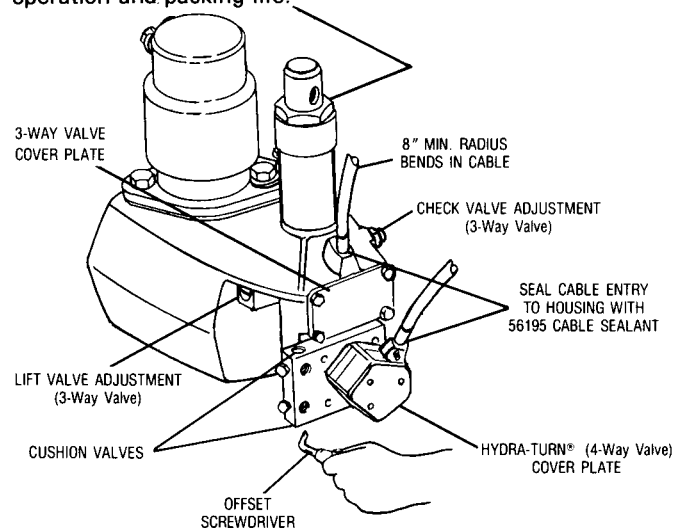

**NOTE:** Manufacturer assumes no liability for accidents or damages notwithstanding the fact that suggestions have been followed.

## B ELECTRICAL DIAGNOSIS

Condition — Motor does not run with cab control in "raise" or "angle" positions. Battery has sufficient charge to start engine.

1. Check all electrical cables and connections. Clean and tighten if necessary.  
**See WARNING ON PAGE 2 BEFORE PROCEEDING.**
2. Ground the primary (small) terminal of the solenoid. If motor runs, problem is in cab control (primary) circuit. Check for broken wire, loose connection or bent contact in cab control. Check if cab control is grounded (through push-pull cables). If the motor does not run . . . .
3. By-pass the secondary (large) terminals of the solenoid. If motor runs, the solenoid is defective and must be replaced. If the motor does not run . . . .
4. Remove motor and check pump shaft. If tight, repair/replace pump. If loose, motor is defective and must be replaced.

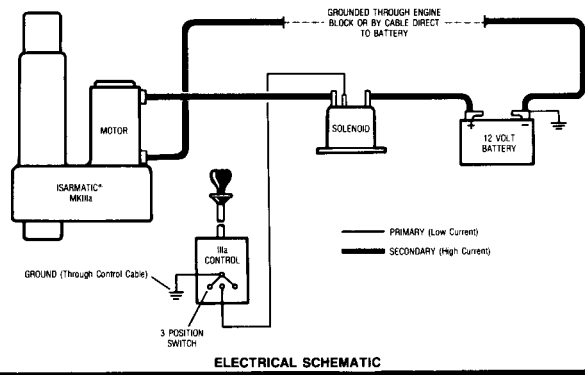

## C

### 3 WAY/4 WAY VALVE TRAVEL

1. Disconnect Hydra-Turn® hoses and lift chain
2. Remove 3-way (lift valve) or 4-way (angle valve) cover plate. Activate cab control in all directions and observe valve lever travel and positions. Lock the cab control in center position with the locking spool. Both valve levers should now be in the neutral position as shown.

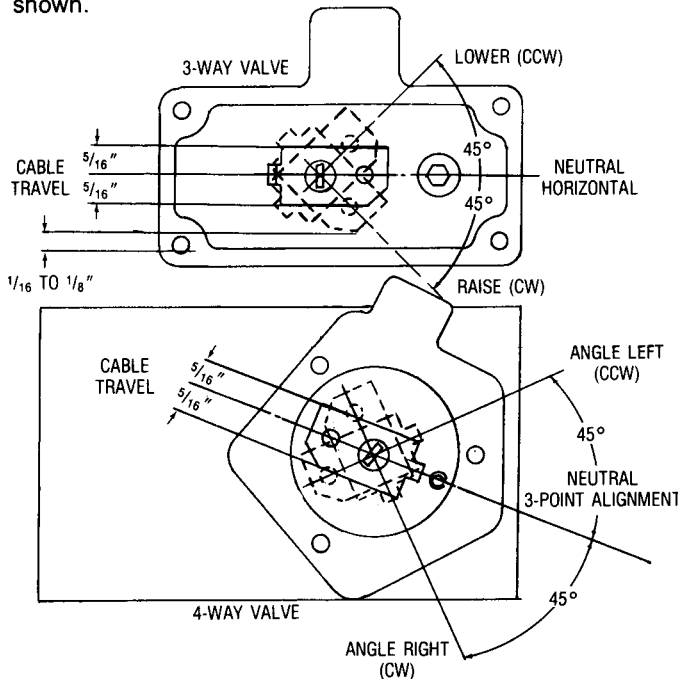

### POSSIBLE CAUSE OF INADEQUATE TRAVEL OR INCORRECT VALVE LEVER POSITIONS

1. Dirt, or ice buildup in enclosure.
2. Cables disconnected in valve enclosure or in cab control.
3. Binding, kinked or broken cable. (8" minimum radius)
4. Set-screw not in groove in cable.
5. Cable out of adjustment or insufficient ring/rotor clearance (4-way valves only).

#### NOTE

If not equipped with adjustable cable, see Service Bulletin SP-595 Page 3.

6. Lift valve too far in (3-way valve only). See E1.

## D

### 4-WAY (ANGLE) VALVE ADJUSTMENT

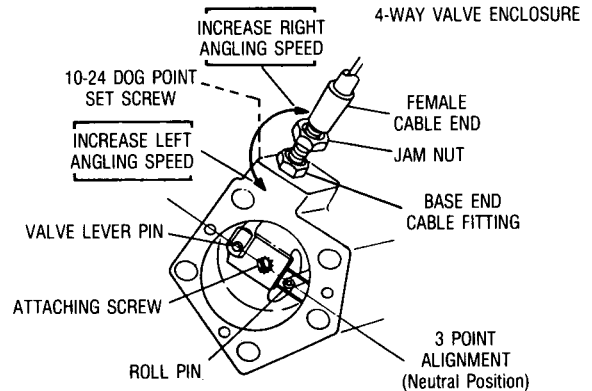

## E1

### 3-WAY (RAISE-LOWER) VALVE ADJUSTMENT (SENSITIVE ADJUSTMENTS - MAX 1/8 TURN AT A TIME)

## E2

#### LIFT VALVE ADJUSTMENT

Disconnect plow before adjusting. If plow will not raise or raises too slowly, turn (CW). If plow raises while angling or angles too slowly, turn out (CCW).

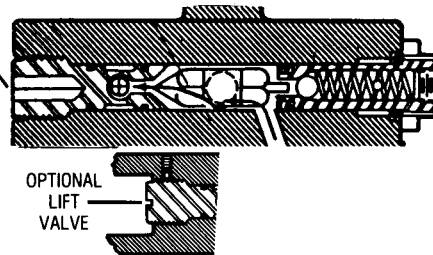

#### CHECK VALVE ADJUSTMENT

If plow will not lower or lowers too slowly, turn in (CW). If plow lowers too fast, turn out (CCW). Hold check valve while loosening or tightening jam nut. To prevent O-ring from blowing out, loosen jam nut 1/4 turn max.

### INITIAL ADJUSTMENT (IF VALVES HAVE BEEN DISTURBED OR REMOVED)

#### LIFT VALVE

Remove cable from pin and place valve lever in neutral position (see C). Turn lift valve in until it is flush to the casting surface. Rotate lever to the "raise" position. It should stop 1/16 to 1/8" from enclosure bottom. If not, turn valve in or out until this dimension is obtained.

#### CHECK VALVE

Turn check valve in until three (3) full threads protrude from the jam nut with jam nut bottomed on housing.

# Isarmatic® Mark IIIa Parts Reference 1½" Ram

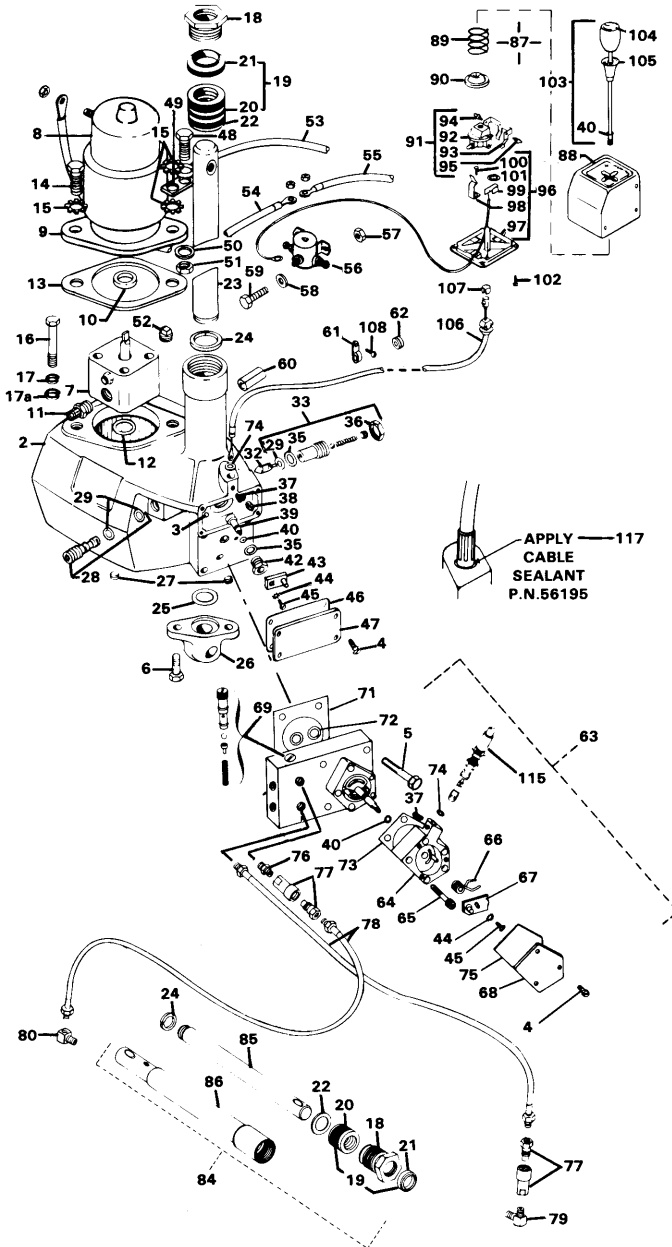

Item	Part No.	Quan.	Description
27	92072	2	Socket Head Pipe Plug — 1/4"
28	49064	1	Lift Valve w/2 #25730 O-Rings
29	25730	2	O-Ring — 012
32	55570	1	Shuttle
33	55568	1	Check Valve Assembly
29	25730	1	O-Ring — 012
35	55587	1	O-Ring — 112
36	55569	1	Jam Nut — 5/8"-18
37	90600	1	Half Dog Point Set Screw — 10-24 x 3/8"
38	92071	1	Socket Pipe Plug — 1/8"
39	55571	1	Camshaft
40	55371	1	O-Ring — 008
35	55587	1	O-Ring — 112
42	55572	1	Hub Nut
43	55573	1	Valve Lever
44	91259	1	Lock Washer 6 — External
45	90655	1	Pan Head Screw 6-32 x 1/4"
46	55350	1	Cover Plate Gasket
47	55958	1	Valve Cover Plate
48	1	1	Capscrew — 3/8"-16 x 3/4"
49	55757	1	Grounding Clip
50	1	1	Lock Washer — 3/8"
51	1	1	Hex Nut — 3/8"-16
52	92079	1	Pipe Plug 3/8"
53	55984	1	Grounding Cable — 60" — 6 Ga.
54	25635	1	Battery Cable — 60" — 4 Ga.
55	22511	1	Battery Cable — 22" — 4 Ga.
56	56131	1	Extra Duty Solenoid Assembly
57	91331	2	Locknut — 1/4"-20
58	1	2	Flat Washer — 1/4" Standard
59	1	2	Capscrew — 1/4"-20 x 3/4"
60	55511	1	Hose Grommet
61	55381	1	Cable Clamp
62	25301	4	Rubber Grommet
63	49020	1	4Way Valve Assembly
37	90600	1	Half Dog Point Set Screw 10-24 x 3/8"
64	55342	1	Cable & Linkage Enclosure
65	90909	5	Socket Head Capscrew — 1/4"-20 x 1-1/2"
66	55359	1	Torsion Spring
67	55364	1	Valve Lever
44	91259	1	Lock Washer 6 — External
45	90655	1	Pan Head Screw — 6-32 x 1/4"
68	55959	1	Enclosure Cover
4	90666	3	Hex Head Tapping Screw — 10-24 x 5/8"
69	49138	1	Cushion Valve Kit (2 Sets)
70	49005	1	4/W Valve Gasket & O-Ring "KIT" (Not shown)
71	55374	1	Manifold Gasket } Not Included
72	55252	2	O-Ring — 015 } w/49020 Valve
40	55371	1	O-Ring — 008
73	55951	1	Shim Spacer .0005 (Silver) Option
73	55735	1	Shim Spacer .00035 (Clear) Option
74	25731	1	O-Ring — 010
75	55357	1	Cover Gasket
76	25519	1	Hex Nipple — 1/4"
77	56132	2	Hydraulic Coupler — 1/4" Poppet
77	25232	2	Hydraulic Coupler — 1/4" Ball
78	55020	2	Hi-Press Hose 1/4" x 38"
79	92278	1	Male Elbow 1/4" x 90°
80	92210	1	Street Ell — 1/4" x 90°
84	56102	2	Hydraulic Cylinder Assembly — 1-1/2" x 10"
18	25944	2	Packing Nut — 1-1/2" Ram
19	25205	2	Packing Set w/Wiper — 1-1/2" Ram
20	55136	2	Packing Set — 1-1/2" Ram
21	55137	2	Wiper Ring — 1-1/2" Ram
22	91167	2	Special Washer — 1-1/2" Ram
85	56105	2	Plunger — 1-1/2" x 10" Ram
24	25203	2	Retainer Ring — 1-1/2" Ram
86	56104	2	Cylinder Unit — 1-1/2" x 10"
87	56018	1	IIIa Control Assembly
88	49021	1	Body w/Label
89	56022	1	Centering Spring
90	56023	1	Spring Retainer
91	49015	1	Platen Assembly
92	1	1	Pivot Platen
93	56026	1	Contact Strip
94	56027	2	Ball Stud
95	93152	1	Hex Head Screw 10 x 3/8" Hi-Lo
96	56028	1	Bottom Cover Assembly
97	1	1	Bottom Cover
98	56030	1	Detent Spring
99	56032	1	Contact Tube Assembly
100	93153	1	Hex Head Screw 6 x 3/8" Hi-Lo
101	93168	1	Retainer Ring 3/8"
102	93154	8	Hex Head Screw 8 x 5/8" Hi-Lo
103	49016	1	Knob & Lever Assembly — Standard
103	49147	1	Knob & Lever Assembly — Short (Optional)
104	56039	1	Lens Label
105	49017	1	Lockspool w/Label
40	55371	1	O-Ring — 008
106	56158	1	Raise-Lower Cable — Short (7-1/2") (Optional)
106	56035	1	Raise-Lower Cable — Standard (9')
106	56180	2	Raise-Lower/Angling Cable - Adjustable - Long (12') (Optional)
115	56159	1	Angling Cable - Adjustable - Short (7-1/2") (Opt.)
115	56130	1	Angling Cable - Adjustable - Standard (9')
74	25731	2	O-Ring — 010
107	49019	1	Ball Stud Retainer Clip
117	56195	1	Cable Sealant
108	1	1	Tapping Screw 10 x 1"

Item	Part No.	Quan.	Description
1	56139	1	Isarmatic® Mark IIIa ED Hydr. Unit w/4W Valve
2	55946	1	Main Housing — 1-1/2" Ram (Service)
3	55591	1	Expansion Plug 1/4"
4	90666	4	Hex Head Tapping Screw 10 x 5/8"
5	93165	4	Capscrew Thread Forming 1/4"-20 x 1-3/4"
6	93166	2	Capscrew Thread Forming 5/16"-18 x 1-1/4"
7	56055	1	Hydraulic Pump Assembly (MTE)
7	49211	1	Hydraulic Pump Assembly (MTE) - Die Cast - (Incl. Items 11, 16, 17, 17a)
8	56133	1	Motor Assembly — 4"
9	49084	1	Flange w/Bearing & Seal — 4"
10	49014	1	Oil Seal Only
11	25639	1	Suction Filter
11	56185	1	Suction Filter — Die Cast Pump
12	25620	1	O-Ring — 115
13	25861	1	Gasket
14	2	2	Capscrew — 7/16"-14 x 1-1/2"
15	91265	3	Lock Washer — 7/16" External
16	93167	2	Capscrew — 5/16"-18 x 2-3/4" (MTE)
16	90025	2	Capscrew — 5/16"-18 x 2-1/4" Gr.5 (Die Cast)
17	2	2	Lock Washer — 5/16" (MTE)
17	91220	2	Belleville Spring Washer (Die Cast)
17a	2	2	Flat Washer — 5/16" Standard (Die Cast)
18	25944	1	Packing Nut — 1-1/2" Ram
19	25205	1	Packing Set w/Wiper — 1-1/2" Ram
20	55136	1	Packing Set — 1-1/2" Ram
21	55137	1	Wiper Ring — 1-1/2" Ram
22	91167	1	Special Washer — 1-1/2" Ram
23	25202	1	Plunger — 1-1/2" x 6" Ram
24	25203	1	Retainer Ring — 1-1/2" Ram
25	25618	1	O-Ring — 216
26	25968	1	Base Lug w/#25618 O-Ring

USE ONLY GENUINE WESTERN® REPLACEMENT PARTS